

PREMIER OFFICE AND INDUSTRIAL SPACE FOR LEASE



SPACE HIGHLIGHTS

- **5,009 Available**
- **Free, Convenient On-Site Parking**
- Positioned in a **well-maintained** and **secured** business park setting
- Accommodates large and small businesses
- Appropriate for light manufacturing, showroom and warehouse/flex applications
- **Google Fiber Available**
- **Clear visibility** and **instant accessibility** to I-35
- **Great location** central to the city's major thoroughfares; moments from the Plaza, Crown Center, Westport and Downtown

LEASING CONTACT

JEREMIAH DEAN, CCIM

P (816) 701-5012

jdean@copaken-brooks.com

MOLLY CRAWFORD MUNNINGHOFF

P (816) 701-5013

mcrawford@copaken-brooks.com

LOCATION

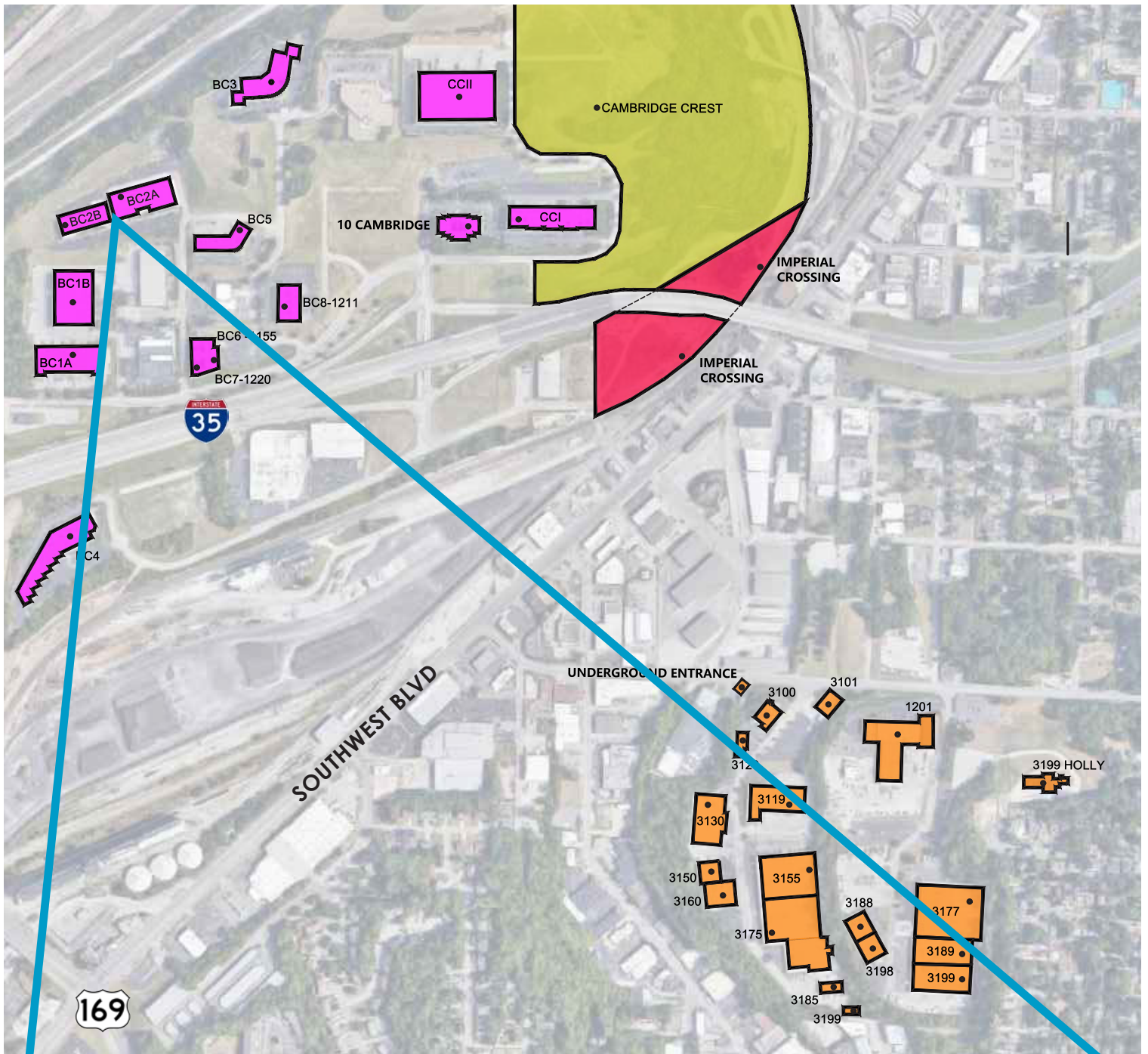

100 ABBIE AVENUE

BUSINESS CENTER 2A

Total SF Available	5,009 SF
Office SF	4,484 SF
Warehouse SF	525 SF
Dock High Doors	1 (8' x 8')
Drive-In Doors	1 (10' x 12')
Clear Height	16'

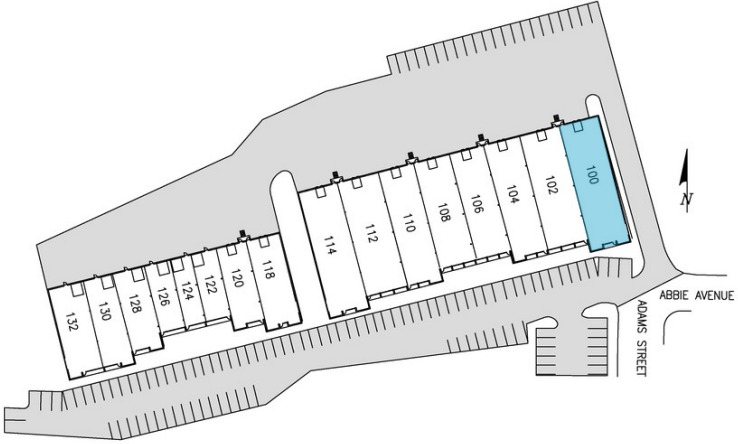

Notes Highway Visibility
Google Fiber Available

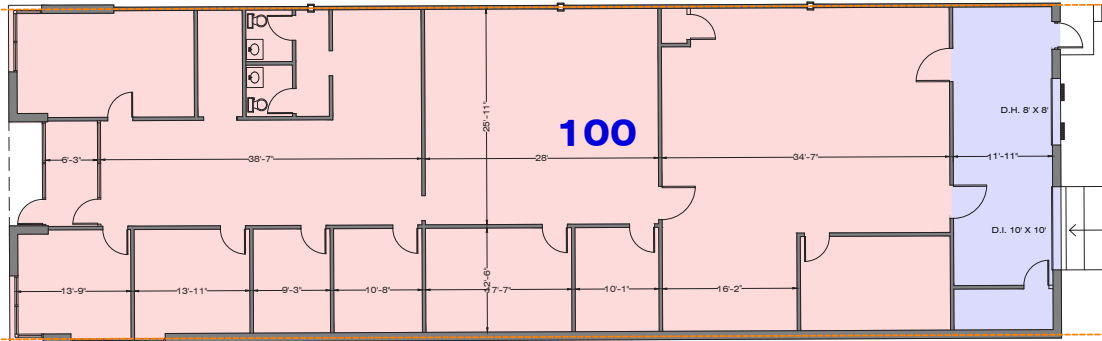

ALTERNATIVE FLOOR PLAN

Total SF	5,009 SF
Office SF	1,508 SF
Warehouse SF	3,501 SF

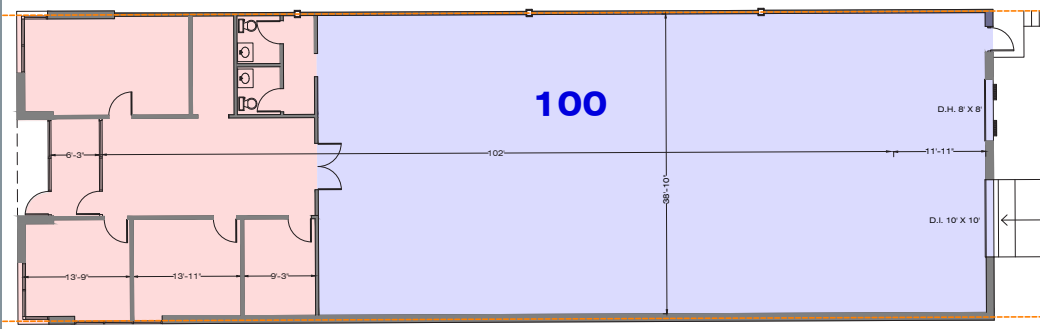

PREMIER OFFICE AND INDUSTRIAL SPACE FOR LEASE



LEASING CONTACT

JEREMIAH DEAN, CCIM

P (816) 701-5012

jdean@copaken-brooks.com

MOLLY CRAWFORD MUNNINGHOFF

P (816) 701-5013

mcrawford@copaken-brooks.com

All information furnished regarding property for sale or lease is from sources deemed reliable, but no warranty or representation is made as to the accuracy thereof and the same is subject to errors, omissions, changes of prices, rental or other conditions, prior sale or lease, or withdrawal without notice.